

Sink Phantom Gun Metal

Kitchen Sinks

Code: 4340 056



DETAILS

Edge/Installation Type	Undermount
Material	AISI 304 stainless steel
Texture	Brushed in line
Finish	PVD
Coloring	Gun Metal
Base	45 cm
Width	41.6 cm
Dimensions	416x416 mm
Bowl dimension	400 x 400 mm

Built-in hole

[View technical data sheet](#)

Standard fittings

Fixing hooks, drain, overflow and siphon, boxed packing

Mixer holes

No standard holes

Drainer

No

Waste fitting

3,5" drain

Number of bowls

1 bowl

FEATURES

Basket 3,5" waste fitting

The drain is equipped with a large 3.5" drain, with the practical basket cap that prevents the discharge of solid parts.

Deep bowls

This bowls reach an important depth, over 20 cm, thanks to the advanced production technology, that can be offer great capiciency and practicity in all the washing operations.

Gun Metal

The Gun Metal finish is obtained by treating steel with a physical process called PVD (Phisical Vacuum Deposition) which deposits particles of noble metals on the surface. The result is a unique and refined aesthetic effect, and an improvement of the mechanical properties of the steel which is more resistant to impact and scratches.

High thickness

1mm thick steel. A significant thickness, which guarantees the maximum sturdiness and durability.

Perimetral overflow

The overflow is always a security on the Foster sinks that prevents the overflow of water in case of oversights. The perimeter drain solution improves aesthetics thanks to its square and essential shape.

Small radius

Bowls with squared shapes with a modern design and an increased capacity, for a minimal aesthetics connected with an extreme practicity.

TECHNICAL DATA

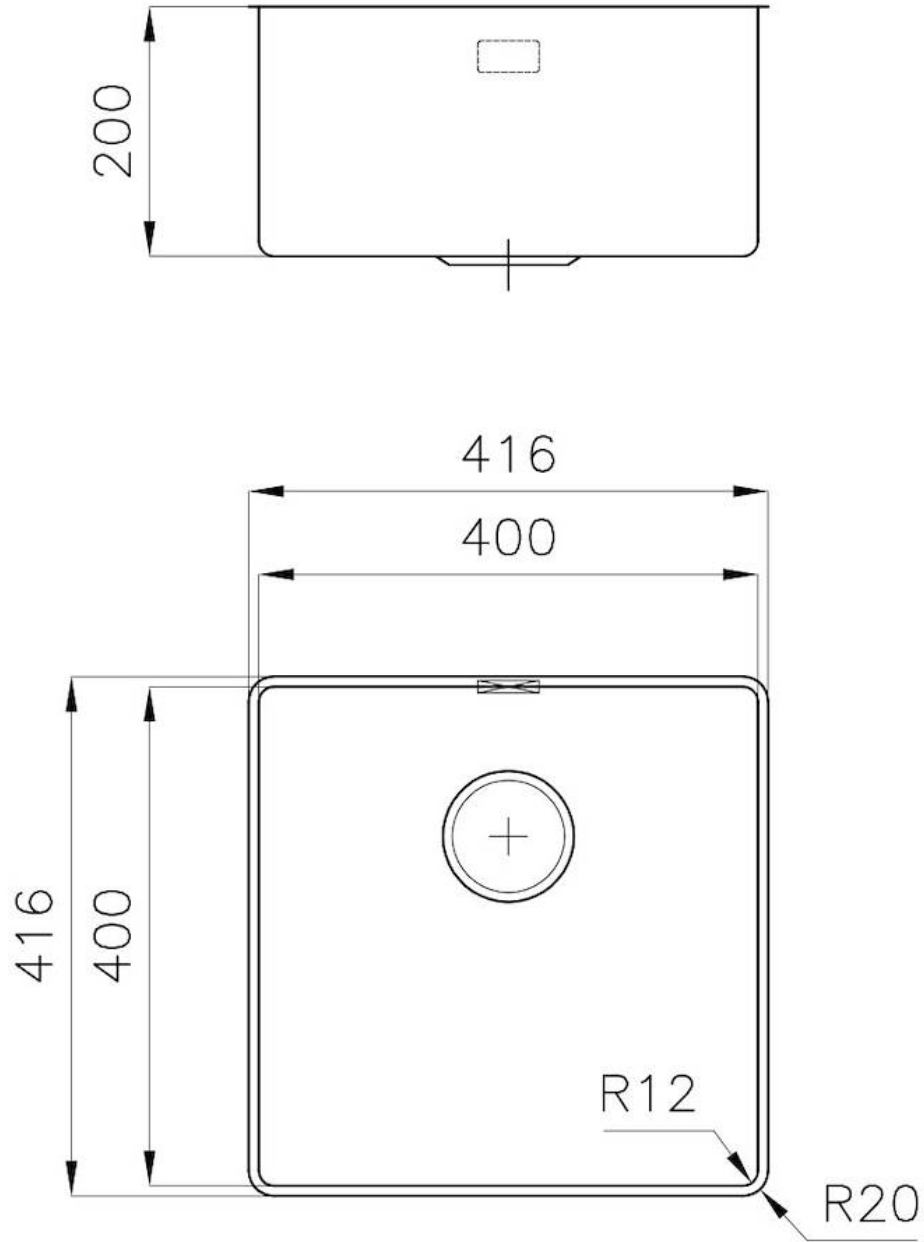



* Lo spessore minimo deve essere valutato in base alla resistenza del materiale

* The minimum thickness must be determined according to the strength of the material

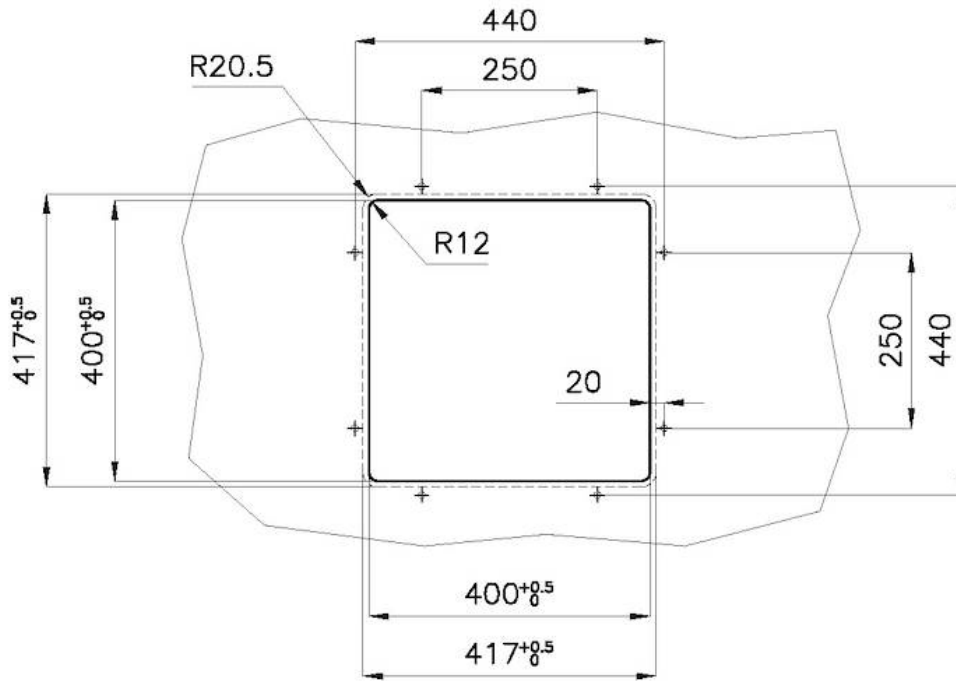

Posizioni fori per fissaggio
Fixing hole positions

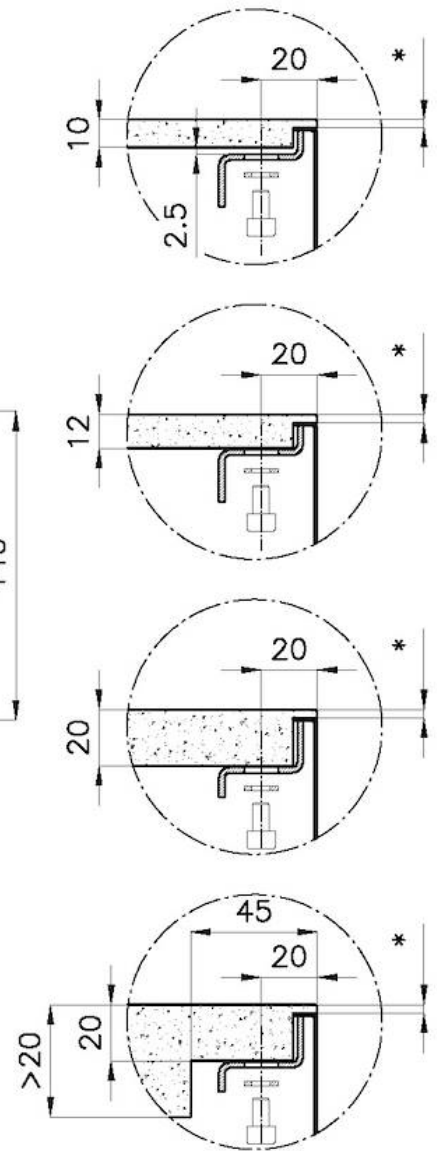

- * Lo spessore minimo deve essere valutato in base alla resistenza del materiale
- * The minimum thickness must be determined according to the strength of the material

GALLERY

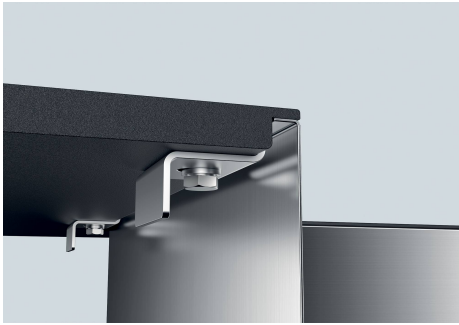

OPTIONAL ACCESSORIES



Cestello inox
8612 000



Glass chopping board
8631 300



HPDE Chopping board
8657 001



HPDE Twin chopping board
8644 101



Stainless steel plate rack
8100 154

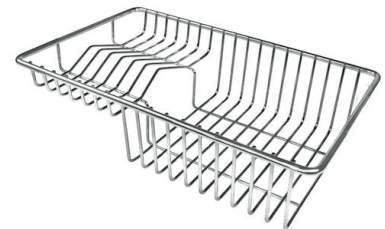

Stainless steel plate rack
8100 303
* only in combination with the accessory
8644 101

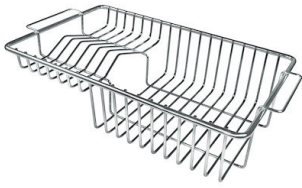

Stainless steel plate rack
8100 201



White bowl
8153 100



Black grid
8100 617



Graters kit with ring-holder and food collection tray
8159 101
* only in combination with the accessory 8644 101



Griglia Black
8100 653



Griglia Black
8100 651



Griglia Black
8100 652



Iroko-wood sliding chopping board with stainless steel colander
8644 044



Stainless steel perforated tray
8151 000
* only in combination with the accessory 8644 101



Stainless steel perforated tray PVD Copper
8151 008



Stainless steel perforated tray PVD Gold
8151 009



Stainless steel perforated tray PVD Gun Metal
8151 006

OPTIONAL AUTOMATIC WASTE FITTINGS



Automatic waste fitting - PM
8407 113



Space automatic waste fitting - PA
8407 108



Space automatic waste fitting - PE
8407 109



**Space Light automatic waste fitting
- PL**
8407 117



**Space Push automatic waste fitting
- PP**
8407 116